



GRUPO INCORPORADO

VITRINA REFRIGERADA

Vitrina refrigerada Grupo incorporado 2 Estantes

CRISTAL RECTO



Temperatura de Trabajo



+1°/+5°

Accesorios disponibles



Pag 82

Especificaciones técnicas



Pag 10

Modelo **A2BF**

- Triple Iluminación LED.
- Puertas correderas en metacrilato hasta primer estante.
- Cristal RECTO
- 2 Estantes con Iluminación LED.
- Perfilería en color PLATA / NOGAL / BLANCO / NEGRO / ACERO INOXIDABLE

A2BF-150



Fabricación Especial **A MEDIDA**

Pídanos Presupuesto

SUPLEMENTO CUBETA

MELAMINA 1/3 h40

4 uds. 6 uds. 8 uds. 10 uds.

48 € 72 € 96 € 120€



Modelo	Largo	Fondo	Alto	Cubetas (Incluidas)	Plata/Nogal/Blanco/Negro	Inox
A2BF-4	1216	410	500	4	1.600 €	1.790 €
A2BF-6	1566	410	500	6	1.730 €	1.940 €
A2BF-8	1926	410	500	8	1.880 €	2.105 €
A2BF-10	2266	410	500	10	2.190 €	2.450 €

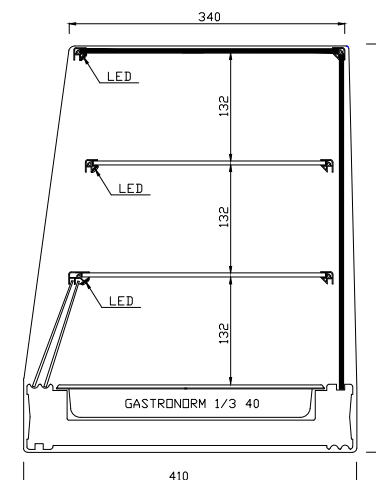

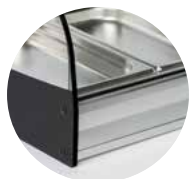

PLATA



NOGAL



BLANCO

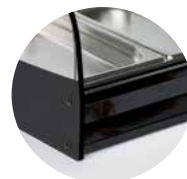

NEGRO

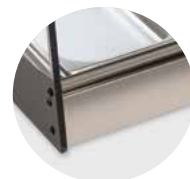

ACERO
INOXIDABLE

GRUPO INCORPORADO VITRINA REFRIGERADA



Triple
Iluminación
LED

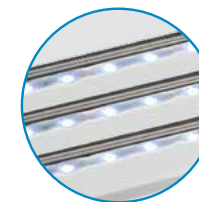

Fabricación Especial
A MEDIDA

Pídanos Presupuesto



A2BF-150 zona trasera

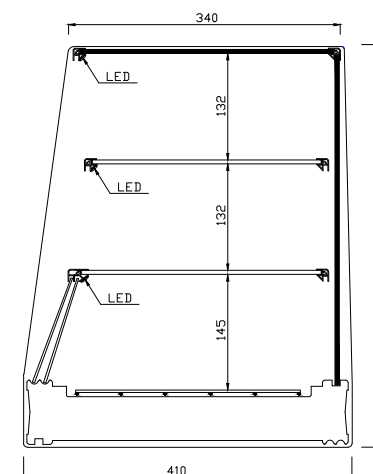

Modelo	Largo	Fondo	Alto	Parrillas (Incluidas)	Plata/Nogal/Blanco/Negro	Inox
A2BF-120	1216	410	500	1.5	1.580 €	1.770 €
A2BF-150	1566	410	500	2	1.710 €	1.920 €
A2BF-200	1926	410	500	3	1.860 €	2.085 €
A2BF-230	2266	410	500	4	2.170 €	2.430 €